

Title: Package outline for 50L TSOP(II)-400mil

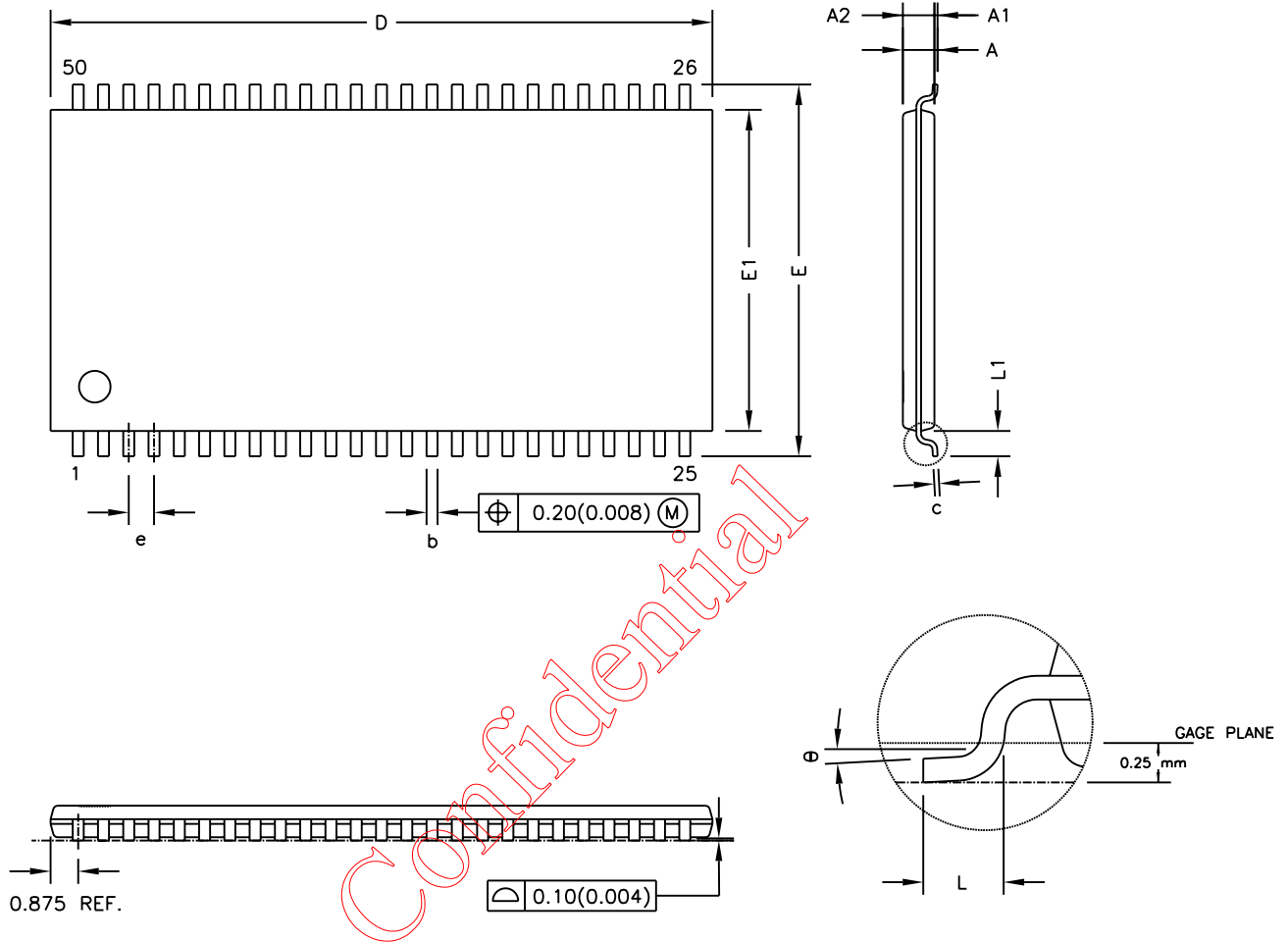

Note: Plating thickness spec : 0.3 mil ~ 0.8 mil.

SYMBOL		A	A1	A2	b	c	D	E	E1	e	L	L1	θ
UNIT													
mm	Min.	-	0.05	0.95	0.30	0.12	20.82	11.56	10.03	-	0.40	-	0°
	Nom.	-	0.10	1.00	0.35	-	20.95	11.76	10.16	0.80	0.50	0.80	-
	Max.	1.20	0.15	1.05	0.45	0.21	21.08	11.96	10.29	-	0.60	-	5°
inch	Min.	-	0.002	0.037	0.012	0.005	0.820	0.455	0.395	-	0.016	-	0°
	Nom.	-	0.004	0.039	0.014	-	0.825	0.463	0.400	0.0315	0.020	0.031	-
	Max.	0.047	0.006	0.041	0.018	0.008	0.830	0.471	0.405	-	0.024	-	5°

DWG. NO.	ORIGINATOR	ISSUE DATE	REV.
PC600-0025	Yuki_Yeh	03-Jan.-'08	1