



File name : CS8818 Application Note

Version: V1.1

Issue Date : 2010/1/4

Total Pages : 11

1. What is LED Constant Current Driver IC?

CHPLUS Constant Current Driver IC is an integrated circuitry device designed for LED applications, specifically suitable for LED signs and LED displays.

** Why need LED Constant Current Driver ICs?

The prominent characteristic of CS8818 is to provide the constant current source, which is able to guarantee the LED stable actuation, eliminates LED the scintillation, is LED demonstrates the high quality brightness the premise.

The chip has 3 kind of characteristics : Current matching, Current Regulation, and Transient Response.

*CS8818 Block Diagram is as below--

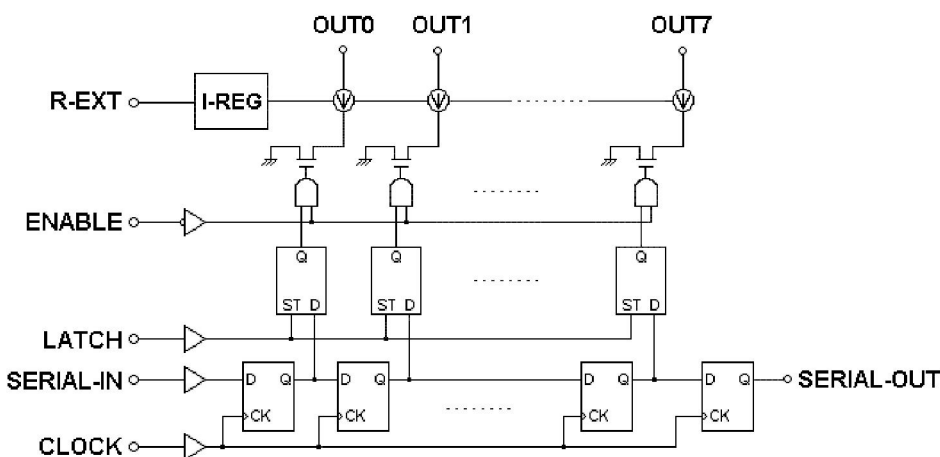

2. How to test/ use LED Constant Driver ?

Between Vss and Pin 15 of CS8818 is set by the external resistor(Rext) and force 5V to Vdd of CS8818. By using digital meter to measure voltage of Pin 15(Vrext). If Vrext of CS8818 is 1.22V, this IC is working properly. If Vrext isn't equal to 1.22V, this IC might not work normally.

****How to control LED output current on/off?**

Excluding Vrext=1.22V, format of input signal Pin goes as follows--

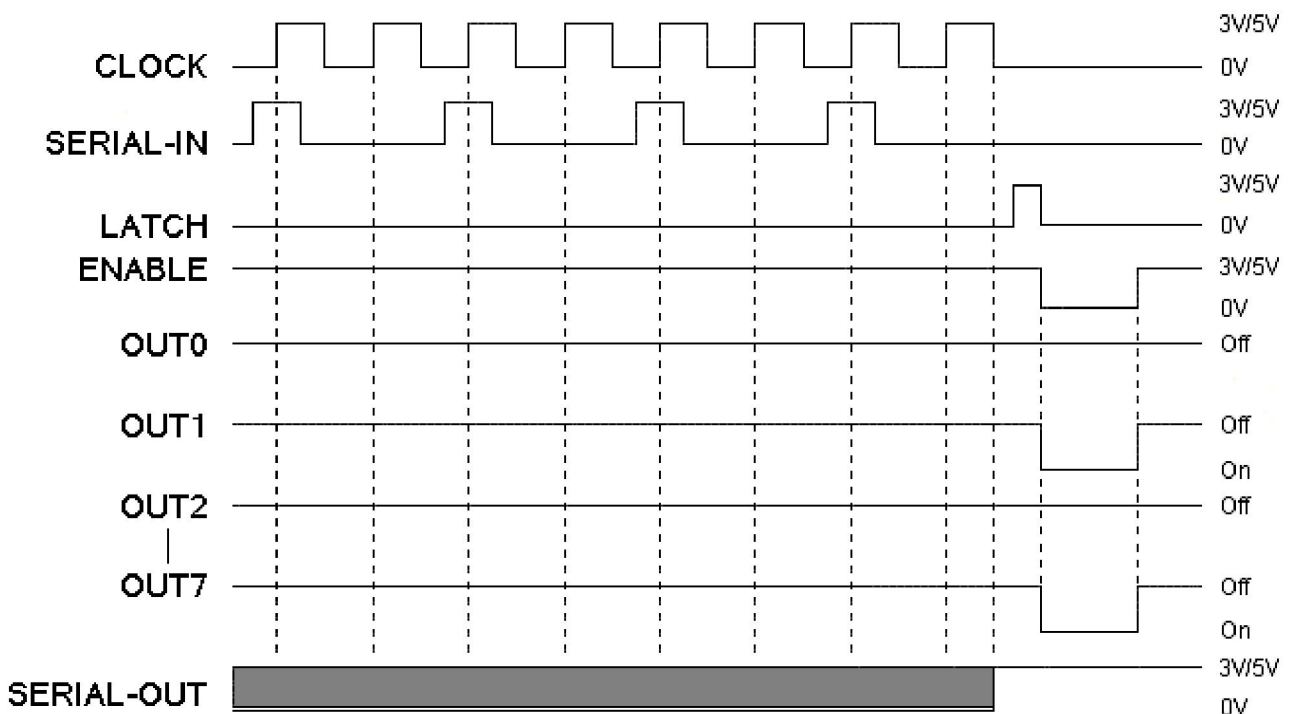

Please refer to the Figure 1 、 Figure 2 、 Figure 3 below for the circuitry .

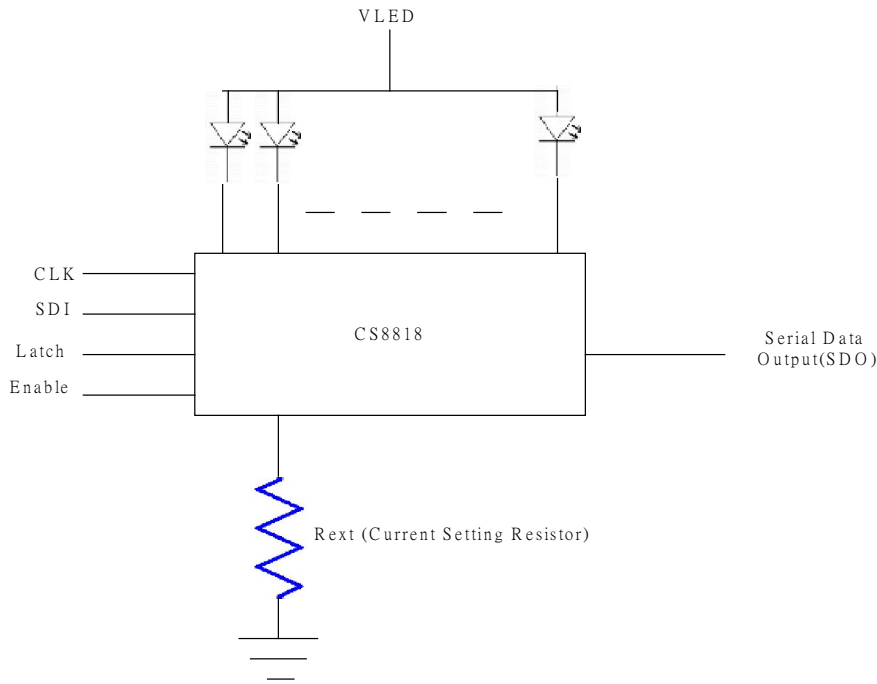

Figure 1: CS8818 Application Example Circuitry

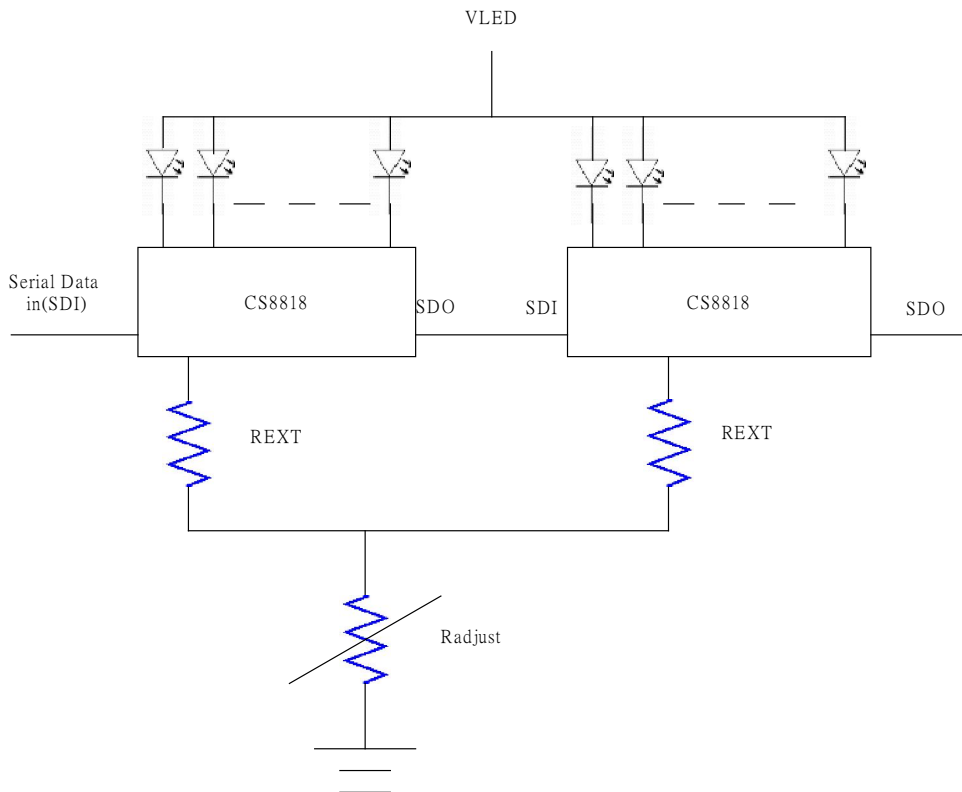

Figure 2: Monochromatic Display Module Example Circuitry

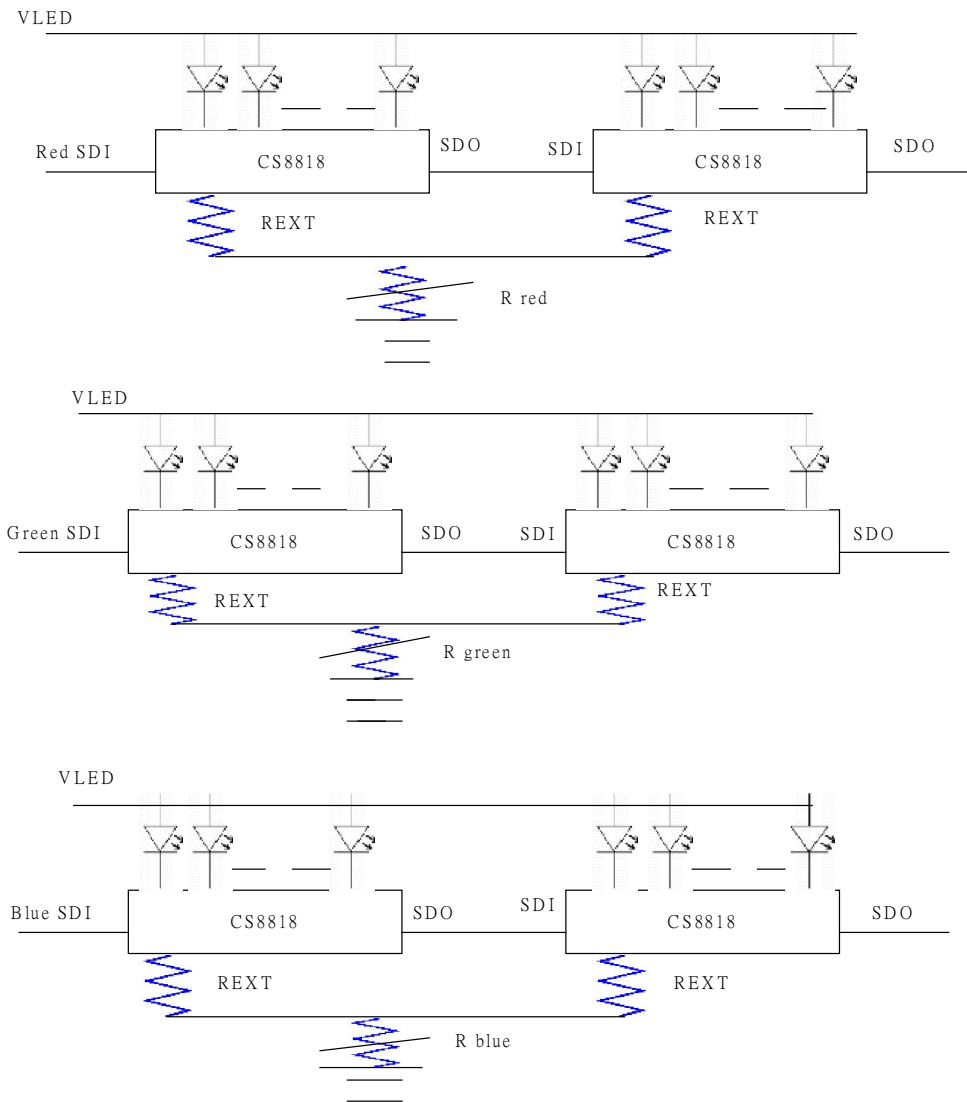

Figure 3: Full color Display Module Example Circuitry

3.How to select output current of LED Constant Current Driver ?

The intensity of output current is set by the external resistor(R_{ext}).

The external resistor(R_{ext}) is a key that determines the current flowing to each output. which current flow then continues the excursion passing the output pins to the ground.

Different resistor correspond to different scales of output current (I_{out}).

The Output Constant Current range of CS8818 is 5~70mA.

The relationship between I_{out} and R_{ext} is shown in the following Figure 4.

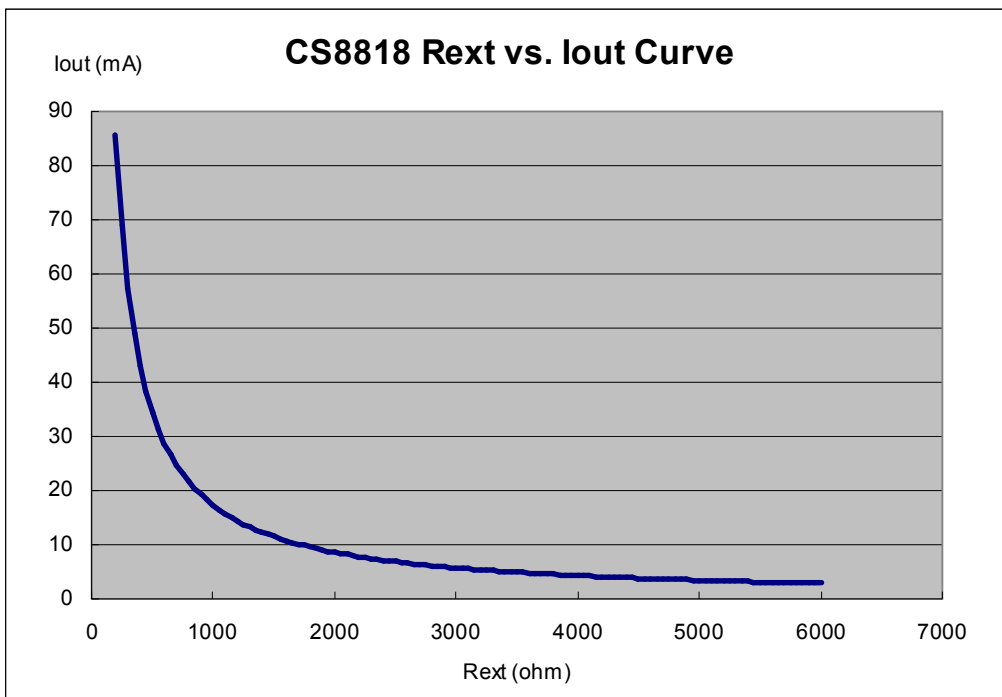

Figure 4: I_{out} and R_{ext} Relationship Curve

Also , the output current can be calculated from the following equation :

$$I_{out} = (V_{R_{ext}} / R_{ext}) \times \text{Current Gain}$$

$V_{R_{ext}}=1.22V$; Current Gain=14.62 (These value are both constant.)

R_{ext} : It is the resistance of the external resistor between CS8818 Pin 15 and ground.

$V_{R_{ext}}$: It is the voltage of R-EXT to Ground terminal.

The magnitude of current(as a function of R_{ext}) is around 25mA at 713Ω .



CS8818 Rext and Iout Relationship Table is as bellow.

	Rext(ohm)							
Iout(mA)	5	6	7	8	9	10	11	12
CS8818	3.57K	2.97K	2.55K	2.23K	1.98K	1.78K	1.62K	1.49K
Iout(mA)	13	14	15	16	17	18	19	20
CS8818	1.37K	1.27K	1.19K	1.11K	1.05K	991	939	892
Iout(mA)	21	22	23	24	25	26	27	28
CS8818	849	811	775	743	713	686	661	637
Iout(mA)	29	30	31	32	33	34	35	36
CS8818	615	594	575	557	540	525	510	495
Iout(mA)	37	38	39	40	41	42	43	44
CS8818	482	469	457	446	435	425	415	405
Iout(mA)	45	46	47	48	49	50	51	52
CS8818	396	387	379	372	364	357	350	343
Iout(mA)	53	54	55	56	57	58	59	60
CS8818	337	330	324	319	313	308	302	297
Iout(mA)	61	62	63	64	65	66	67	68
CS8818	292	288	283	279	274	270	266	262
Iout(mA)	69	70						
CS8818	259	255						

After appropriate I_{out} value is selected, an adequate scale of V_{ds} (Output LED power) is then required to ensure the stable operation at saturation.

In general, for programmed current 25mA , a minimum V_{ds} of 0.7V is highly recommended for proper current regulation. For programmed currents of 25mA or above , a minimum V_{ds} of 1.0V is instead suggested. Figure 5 illustrates the relationship between V_{ds} and I_{out} curve.

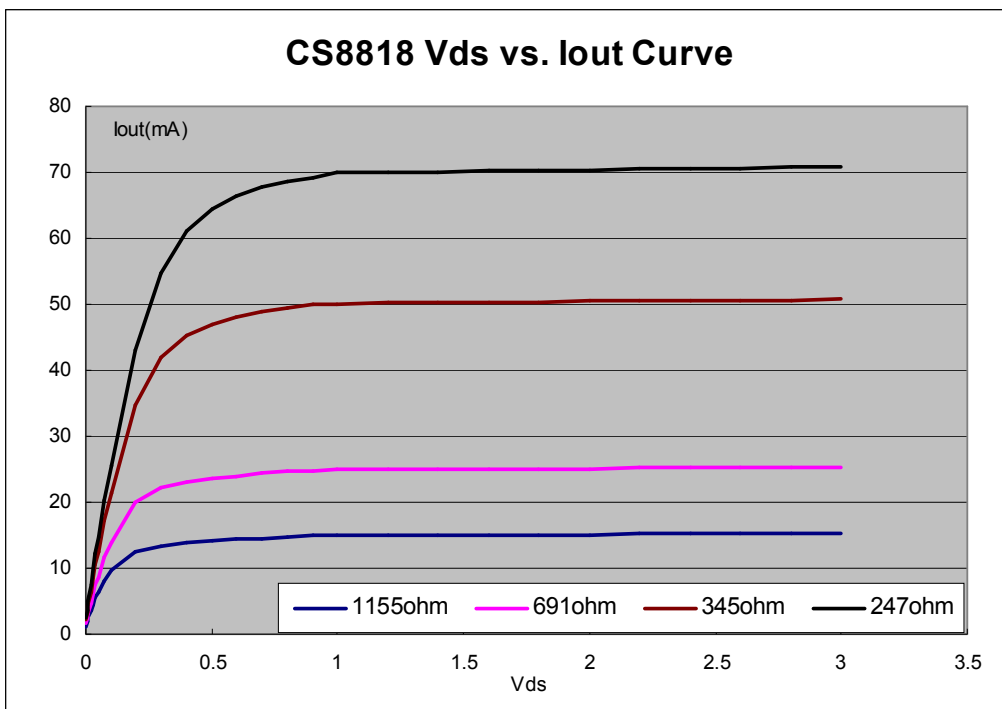

Figure 5 I_{out} vs V_{ds} Relationship Curve

4. Notice for PCB layout:

In LED application circuitry, electromagnetic effect is mostly resulted from the board layout. The current flow, the on-off switching characteristic and the power regulation may cause the Driver IC malfunction.

The Driver IC may be damaged by the over-voltage stress owing to the parasitical inductance, LED and power supply, in output terminals. In addition, the unstable supplying voltage will obviously influence the quality of image.

In order to improve these abnormal operation, CHIPLUS give example circuitry for reference application only. Please refer to Figure 6, Figure 7, and Figure 8 in below.

Whose brief introduction goes--

A. PNP BJT of Figure 6、Figure 7、Figure 8, the main chip could control the scanning function on different LED cells simultaneously.

B. R1 of Figure 6、Figure 7、Figure 8, the setup resistance for the setup of output current of every IC.

C. R2 of Figure 6、Figure 7、Figure 8, the variable resistance for the brightness control of every LED module.

D. Zener Diode of Figure 7, the unnecessary voltage is one effective technique as to making the voltage descend With the Zener Diode.

E. R3 of Figure 8, it can improve on surplus V_{out} causes an IC fever and the useless consumption Electric power

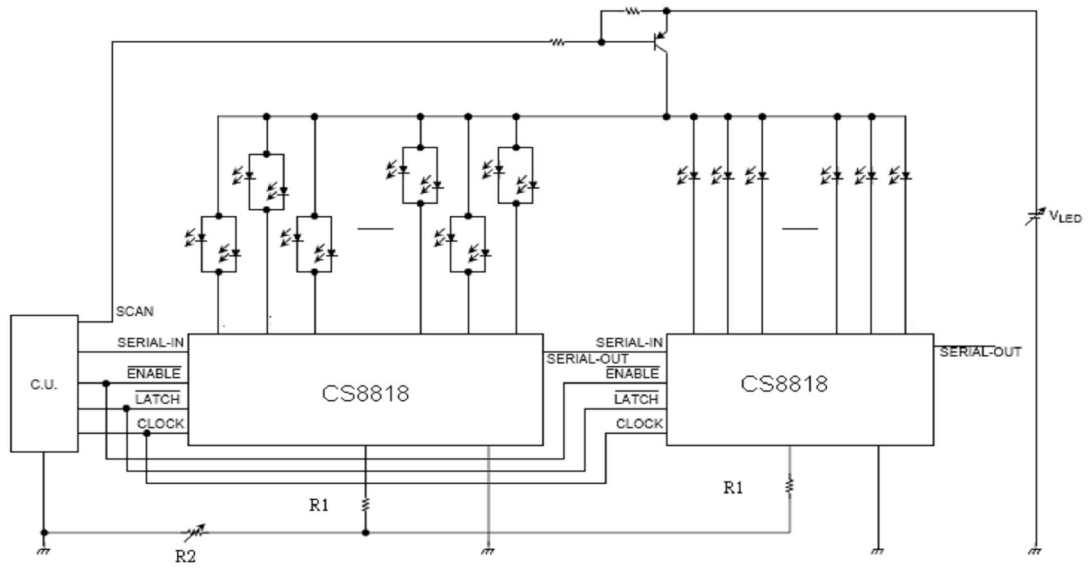

Figure 6: The general circuitry

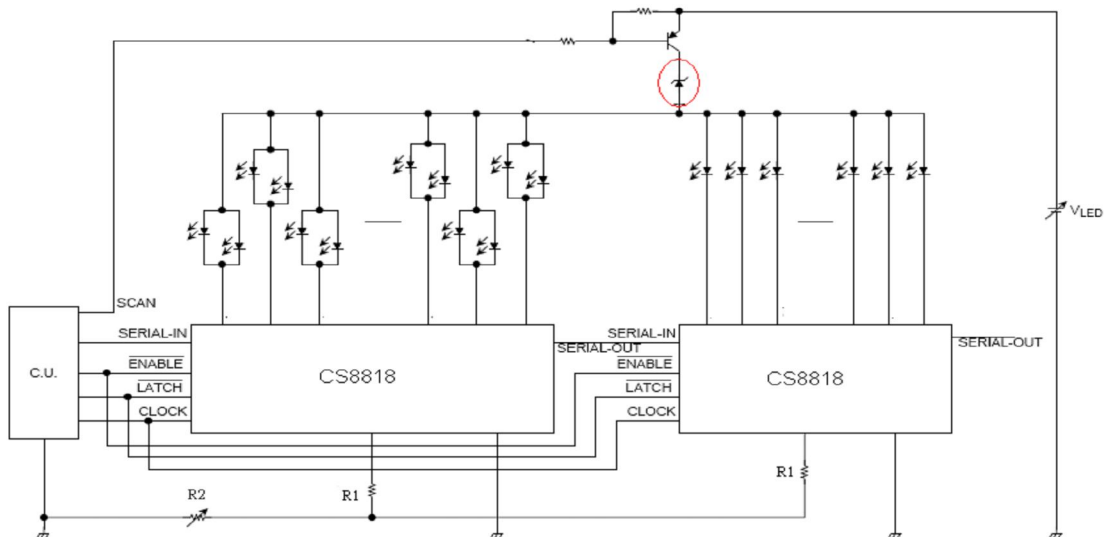

Figure 7: Addition of Zener Diode

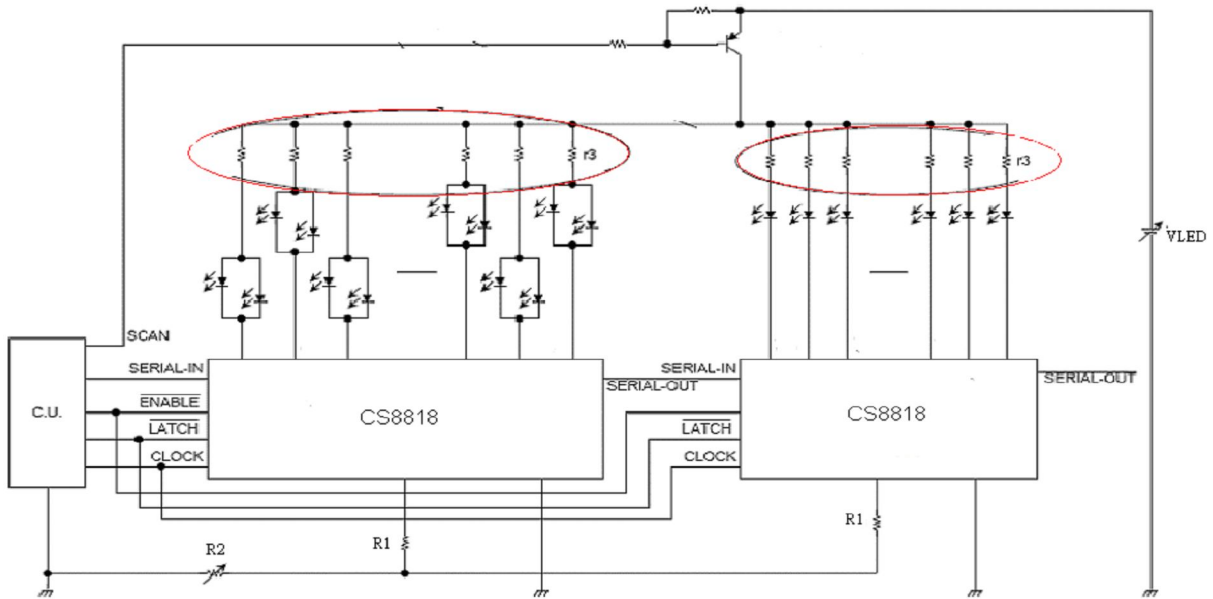

Figure 8: Addition of R3